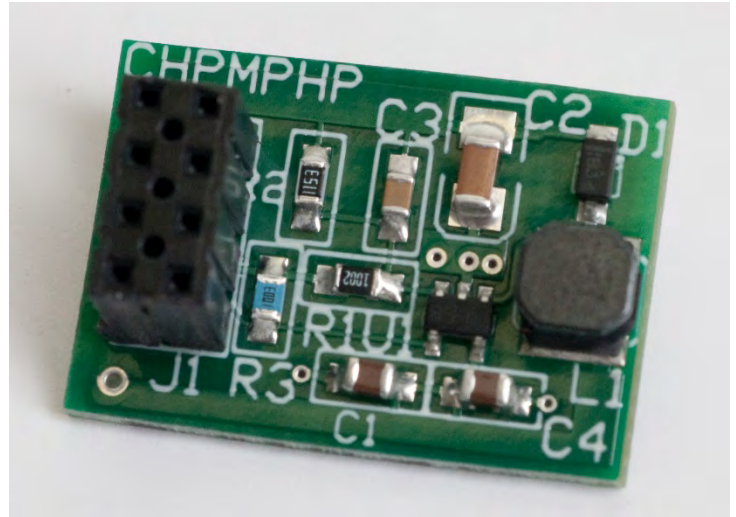
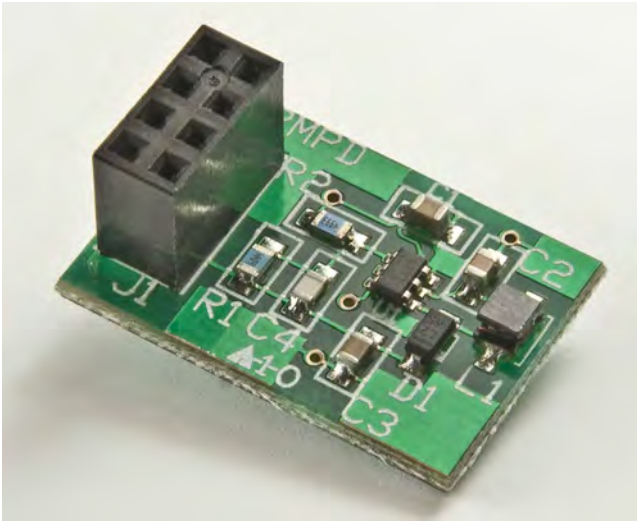

IS-CHPMP and IS-CHPMPHP Manual

Revision D

**NKK SWITCHES**7850 E. Gelding Drive
Scottsdale, AZ 85260

Toll Free 1-877-2BUYNKK (877-228-9655)

Phone 480-991-0942

Fax 480-998-1435

e-mail <engineering@nkkswitches.com>

All Rights Reserved Worldwide

NKK Switches makes no warranty for the use of these products and assumes no responsibility for any errors, which may appear in this document, nor does it make a commitment to update the information contained herein. Smart Switch is trademark of NKK Switches.

TABLE OF CONTENTS

Table of Contents	2
1. General Description	3
2. Electrical Characteristics	5
3. Pin Configurations	5
4. Multi-Switch Operation	6
5. Schematic	7
6. Build of Material	8
7. Board Layout	9
8. Dimensions	9

1. General Description.

There are two different charge pumps; IS-CHPMP and IS-CHPMPHP. They are designed for different uses.

OLED products supported by the charge pumps.		
	IS-CHPMP	IS-CHPMPHP
OLED Switch	ISC15ANP4	ISC15ANP4
OLED Display	ISC01P	ISC01P
OLED Rocker	IS18IA001	IS18IA001
Frameless OLED	-	ISF15ACP4

The IS-CHPMP is a DC/DC voltage step-up converter with an input of 2.7-5.5V and an output of **16V** for use in driving OLED displays. The IS-CHPMP utilizes Maxim’s MAX8574 step-up converter to take advantage of its floating output during shutdown mode. A 2x4 .100” header is required to interface with charge pump.

The IS-CHPMPHP is a DC/DC voltage step-up converter with an input of 2.7-5.5V and an output of **15V** for use in driving OLED displays. The IS-CHPMPHP utilizes LM2735YMF/NOPB step-up converter to take advantage of its floating output during shutdown mode. A 2x4 .100” header is required to interface with charge pump.

IS-CHPMP and IS-CHPMPHP are RoHS compliant.

Photo 1, IS-CHPMP, Primary side

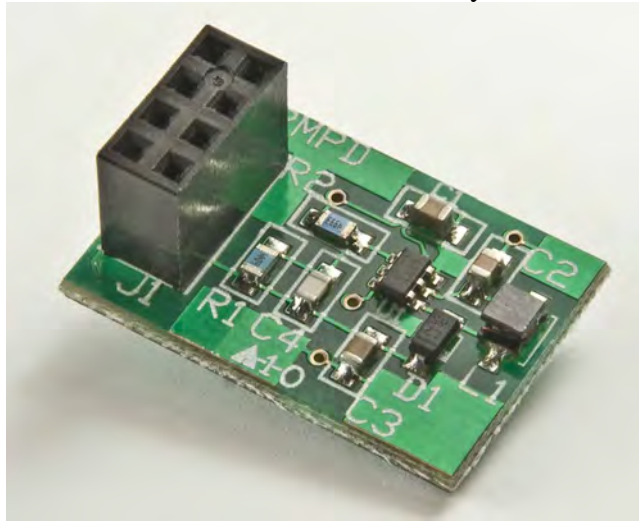

Photo 2, IS-CHPMP, Secondary side

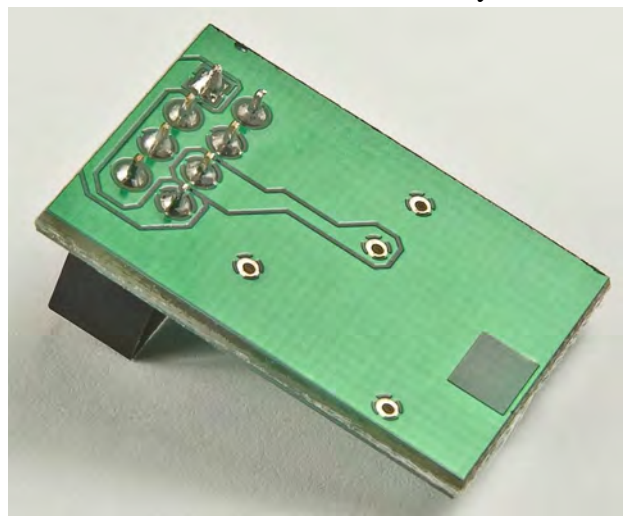

Photo 3, IS-CHPMPHP, Primary side

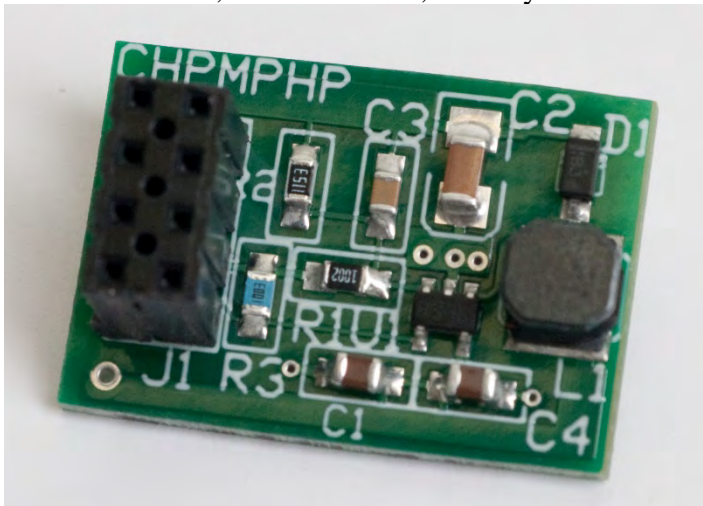

Photo 4, IS-CHPMPHP, Secondary side



2. Electrical Characteristics

IS-CHPMP	IS-CHPMPHP
2.7-5.5V Input Voltage.	2.7-5.5V Input Voltage.
16V Output Voltage.	15V Output Voltage.
Floating output when in shutdown mode.	Floating output when in shutdown mode.
Current Capability: 20mA	Current Capability: 130mA
Does not have pulldown resistor for disable.	Has pulldown resistor for disable.
Current .05uA typical, 1uA maximum in shutdown mode.	Current .05uA typical, 1uA maximum in shutdown mode.

3. Pin Configurations

IS-CHPMP		
Pin	Name	Function
1	V3.3	Input voltage supply between 2.7-5V.
2	V16	Output voltage preset to 16V.
3	SHTDN	Shutdown input. A logic high puts the MAX8574 into normal operation. A logic low at SHTDN places the MAX8574 into low-power shutdown mode. Does not have pulldown resistor for disable.
4	GND	Ground
5	GND	5 connected to 4
6	SHTDN	6 connected to 3
7	V16	7 connected to 2
8	V3.3	8 connected to 1

IS-CHPMPHP		
Pin	Name	Function
1	V3.3	Input voltage supply between 2.7-5V.
2	V16	Output voltage preset to 15V.
3	SHTDN	Shutdown input. A logic high puts the LM2735Y into normal operation. A logic low at SHTDN places the LM2735Y into low-power shutdown mode. Has pulldown resistor for disable.
4	GND	Ground
5	GND	5 connected to 4
6	SHTDN	6 connected to 3
7	V16	7 connected to 2
8	V3.3	8 connected to 1

Note: Incorrect installation of the connector could damage the charge pump and/or the motherboard.

Illustration 1, Pin Configuration in relation to board, IS-CHPMP

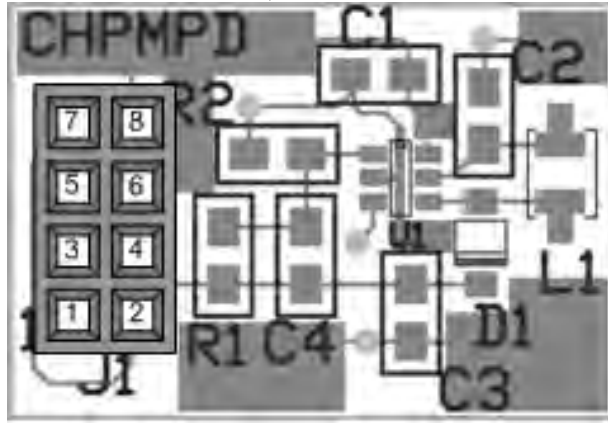
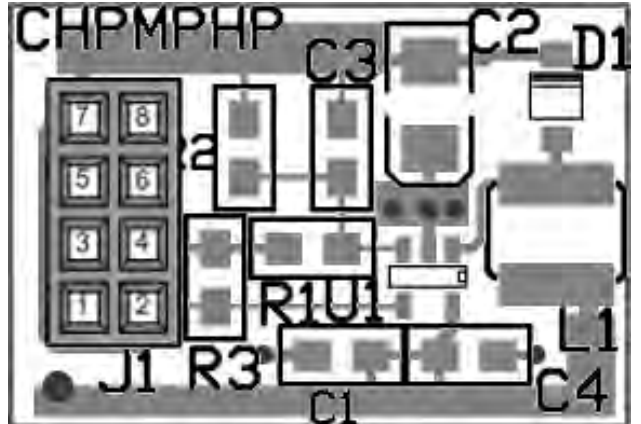

Illustration 2, Pin Configuration in relation to board IS-CHPMPHP



4. Multi-Switch Operation

OLED power consumption is based on the number of pixels on. The safe way to calculate the number of OLED products that can be powered by one charge pump is as stated below:

$$\text{Number of OLED products} = \frac{\text{Charge Pump Current Capability}}{\text{AllPixelsOn Mode Max Current}}$$

It is possible to have more OLED products powered by one charge pump since under normal operation not all the pixels are on at the same time.

If more OLED product need to be powered, then multiple charge pumps can be placed in parallel.

5. Schematic

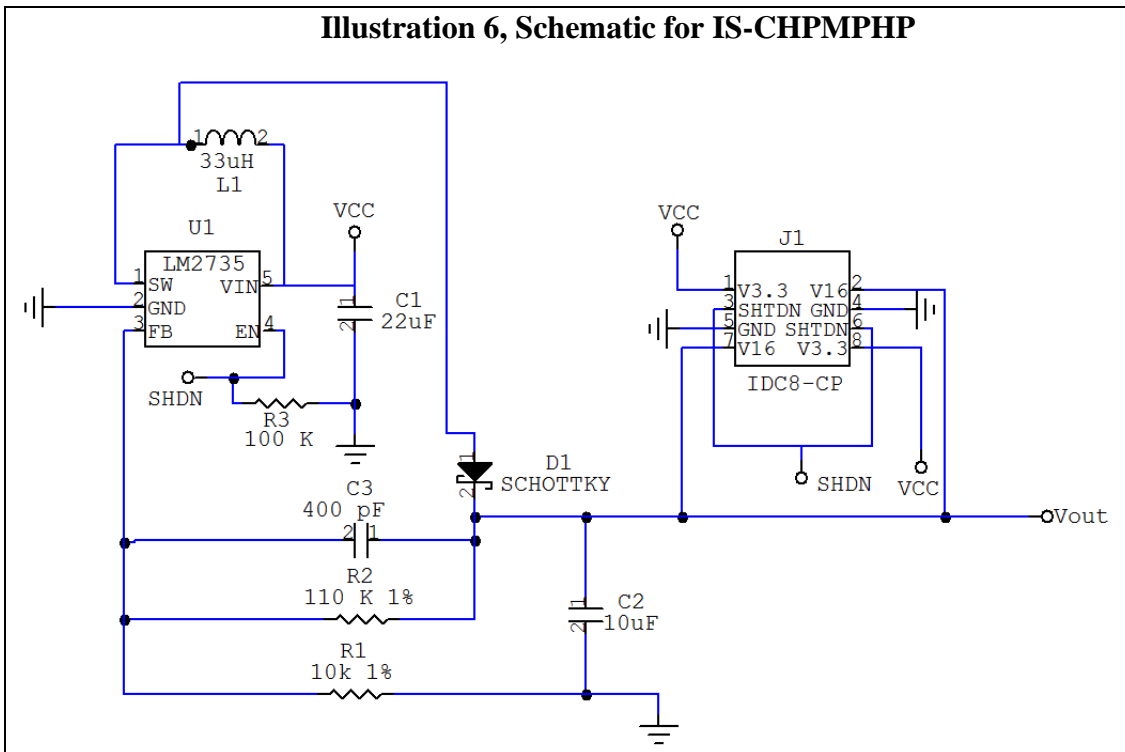
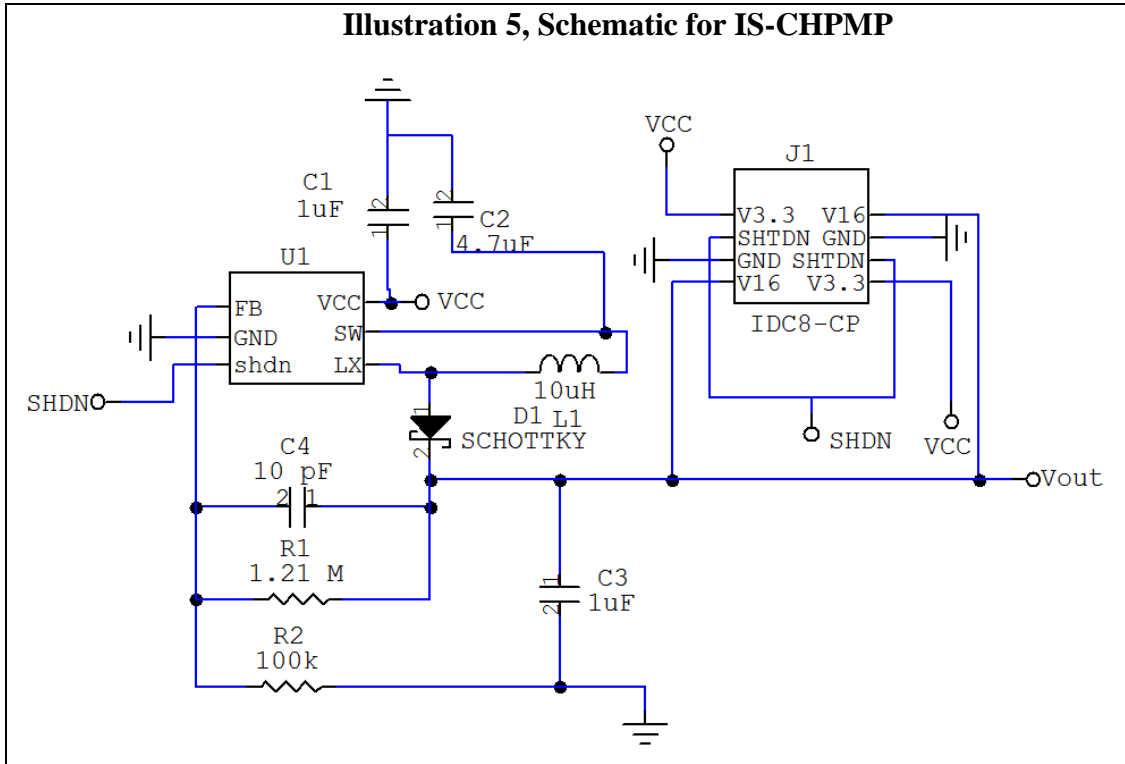

6. Build of Material

BOM for IS-CHPMP						
Item	Count	Designation	Part Number	Description	Value	Package
1	1	-	P-CHPMPD	PCB/OLED CHARGE PUMP/REV D	-	-
2	1	C1	MA0805XR105K160R	CAPACITOR, 1uF, SM0805, 16V, X7R	1UF	SM0805
3	1	C2	C2012X5R0J475K	CAPACITOR, 4.7uF, SM0805, 6.3V, X5R	4.7UF	SM0805
4	1	C3	GRM219R71E105KA88D	CAPACITOR, 1uF, SM0805, 25V, X7R	1UF	SM0805
5	1	C4	GRM2165C1H4R7CD01D	CAPACITOR, 4.7pF, SM0805, 50V, COG	4.7PF	SM0805
6	1	D1	BAT42W-V-GS08	DIODE, SCHOTTKY, SOD-123, 0.200A, 30V		SOD-123
7	1	J1	PPPC042LFBN-RC	HEADER, 2x4, RECEPT, FEMALE, .100", THU, STRAIGHT, GOLD	2x4	THR HOLE
8	1	L1	LQH32CN100K33L	INDUCTOR, 10uH, 450MA, 0.300 OHM, SMD	10UH	SMD
9	1	R1	RK73H2ATTD6044F	RESISTOR, 6.04M, SM0805, 1/8W, 1%	6.04M	SM0805
10	1	R2	RK73H2ATTD4993F	RESISTOR, 499K, SM0805, 1/8W, 1%	499K	SM0805
11	1	U1	MAX8574EUT+T	IC, SOT-23-6, LCD STEP-UP DC-DC CONVERTER, 500mA, 2.7V TO 5.5V		SOT-23-6

BOM for IS-CHPMPHP						
Item	Count	Designation	Part Number	Description	Value	Package
1	1	-	P-CHPMPHP	PCB, CHARGE PUMP HIGH POWER, Rev C	-	-
2	1	C1	C2012X5R0J226M/1.25	CAPACITOR, 22uF, SM0805, 6.3V, X5R	22uF	SM0805
3	1	C2	C3216X5R1E106M	CAPACITOR, 10uF, SM1206, 25V, X5R	10uF	SM1206
4	1	C3	CC0805KRX7R9BB471	CAPACITOR, 470pF, SM0805, 50V, X7R	470pF	SM0805
5	-	C4	-	-	-	-
6	1	D1	MBR0530	DIODE, SCHOTTKY, SOD-123, 0.5A, 30V		SOD-123
7	1	J1	929975-01-36	HEADER, 2x36, .100", THU, FEMALE, STRAIGHT	Cut 2x4	THR HOLE
8	1	L1	74404054330	INDUCTOR, 33uH, 1.2A, 189 mOHM, SMD	33UH	SMD
9	1	R1	RMCF0805FT10K0	RESISTOR, 10K, SM0805, 1/8W, 1%	10K	SM0805
10	1	R2	RC0805FR-07110KL	RESISTOR, 110K, SM0805, 1/8W, 1%	110K	SM0805
11	1	U1	LM2735YMF/NOPB	VOLTAGE REGULATOR, SOT23-5, STEP-UP, 520kHz, ADJ O.P. 3-24V, 2.1A		SOT23-5

7. Board Layout

Illustration 7, Primary side

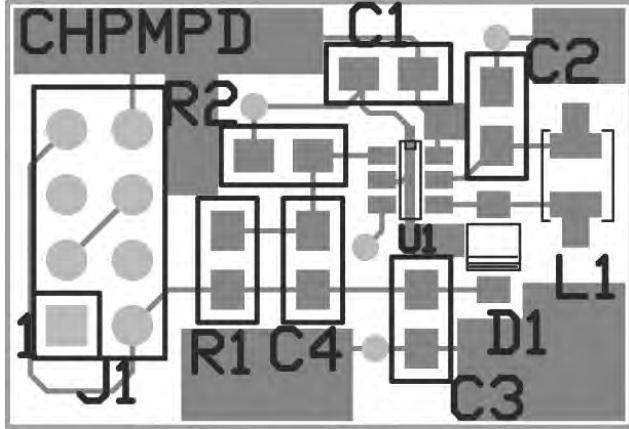

8. Board Layout for IS-CHPMP

Illustration 8, Secondary side

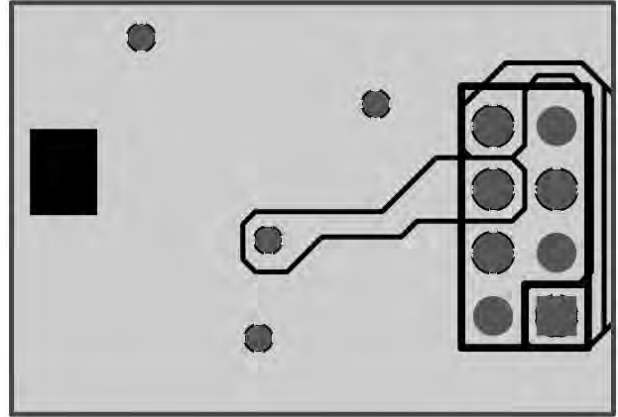

Note: No traces or ground plane shall be present under the inductor.

Board Layout for IS-CHPMPHP

Illustration 9, Primary side

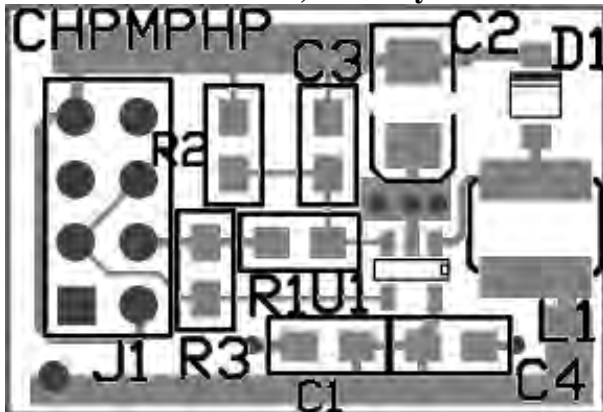
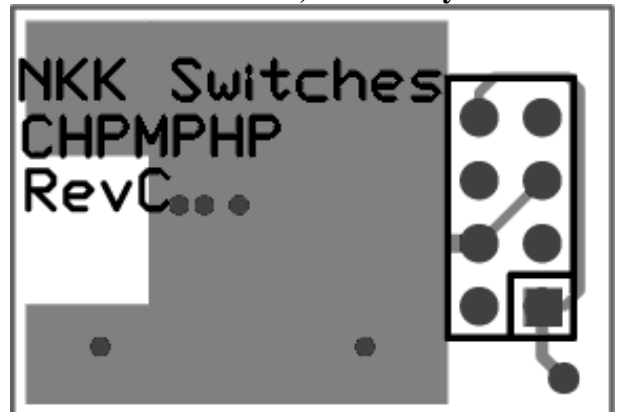
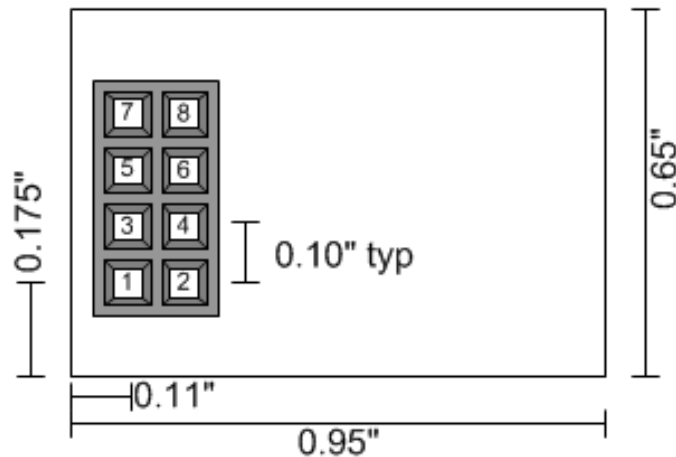

Illustration 10, Secondary side



Note: No traces or ground plane shall be present under the inductor.

9. Dimensions



Warranty

NKK SWITCHES LIMITED WARRANTY AND LIMITATION OF LIABILITY

The following limits our liability. Please read.

NKK Switches hereby warrants this product against any and all manufacturing defects for a period of one year from the date of sale of this product to the original end user. NKK Switches' liability in the event of such defect is limited to repair or replacement of the defective products. NKK Switches disclaims any liability or warranty obligation with respect to any product that is misused, damaged by any user, or not used in conformity with all applicable product specifications.

NKK SWITCHES HEREBY DISCLAIMS ANY WARRANTY, EXPRESS OR IMPLIED, OTHER THAN THAT CONTAINED HEREIN. NKK SWITCHES EXPRESSLY DISCLAIMS THE WARRANTIES OF MERCHANTABILITY AND FITNESS FOR A PARTICULAR PURPOSE, AND SHALL HAVE NO LIABILITY BASED ON OR ARISING FROM ANY CLAIM OF SUCH WARRANTY.

NKK Switches shall have no liability to any person for any incidental, consequential, special, punitive, or other damages of any kind whatsoever relating to any use of this product.

USE OF THIS PRODUCT IN CONNECTION WITH ANY LIFE CRITICAL APPLICATION IS NOT RECOMMENDED.