



Bright or Super Bright LEDs

Square or Round

Bushing Mount

Resistant to Tampering

IP65 Panel Seal Compliance

Bezels in Black, Brushed Chrome

Short, Compact Body

Long Life Models

Crisp, Light Touch Actuation

Distinctive Long Stroke

Standard or Custom Legends

Value Added Services

NKK's Value Added Services provides multiple benefits for standard product offerings and coordinates seamlessly with customer specific requirements. Services include custom electronic or electromechanical assembly, soldering, crimping, heat shrink or epoxy. Printing services are an ideal fit for the YB2 Series, on the cap or film insert. Screen printing, pad printing or laser etching are offered to customize and add distinction to any panel configuration.



The Value Added Services facility with ISO:9001 certification provides affordable enhancements that release the customer to manage other aspects of the project. NKK's team of proficient engineers and technicians are available to offer innovative solutions and support.

Series YB2 Illuminated Pushbuttons

This standard size series of illuminated pushbutton switches presents a plethora of options to enhance panel appearance and applications. The series is rated IP65 at the front panel and offers choices in round or square actuator shapes and sizes, bezels, LED colors, and caps. Both silver and gold rated contacts are options, and the UL marking is available on specific models. A variety of standard legends is offered, or custom symbols or graphics are accessible through NKK's Value Added Services.

Be assured that regardless of the part number, the product will be a representation of NKK Switches' superior quality and commitment to excellence. Contact our engineers and switch specialists to discuss solutions and support.

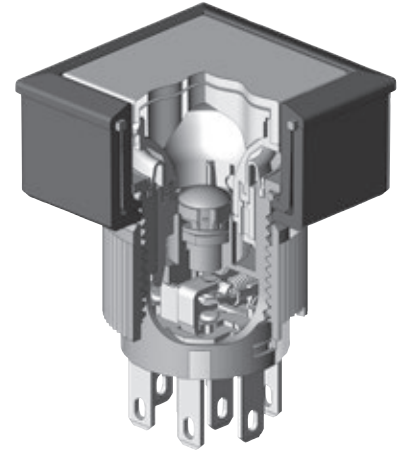

PANEL SEAL PUSHBUTTONS

Characteristics & Specifications

YB2 Series Miniature Pushbuttons

- Round 25mm or square 24mm pushbuttons with minimal .071" (1.8mm) above-panel dimension
- Super bright LEDs in white, green or blue; bright LEDs in red, amber or green
- Dust tight and splashproof panel seal protection quality to IP65 of IEC 60529 Standards
- Tamper resistant actuators in 18mm square or 19mm diameter
- Short, compact body of .965" (24.5mm) conserves behind-panel space
- Light touch actuation and distinctive long stroke clearly indicate circuit status
- Multiple cap color options enhance panel design, including metallic silver cap with bright ring illumination (for round models)
- Choice of bezels in black or brushed chrome
- Available in momentary or alternate action with latching
- Combination solder lug and .110" quick connect terminals are epoxy sealed, prohibiting entry of flux, dust, solvents and other contaminants, plus improving contact stability
- Value Added Services includes legends on actuator or film insert; wire harnesses or various custom assemblies also available to enhance design and efficiency

Resistive Load

Power Level (silver): 3A @ 125V AC; 3A @ 250V AC; 3A @ 30V DC
Logic Level (gold): 0.4VA max @ 28V AC/DC max
(Applicable Range 0.1mA ~ 0.1A @ 20mV ~ 28V)

Contact Resistance: 50 milliohms max for silver
100 milliohms max for gold

Insulation Resistance: 200 megohms min @ 500V DC

Dielectric Strength: 1,000V AC min between contacts for 1 minute min;
1,500V AC min between contacts & case for 1 minute min

Mechanical Life: 1,000,000 operations min for momentary circuit
200,000 operations min for maintained circuit

Electrical Life: 100,000 operations min

Nominal Operating Force:

Single Pole: 1.5N; Double Pole: 3.0N

Contact Timing: Nonshorting (break-before-make)

Pretravel .059" (1.5mm); Overtravel .059" (1.5mm);
Total Travel .118" (3.0mm)

Operating Temperature Range:

Illuminated: -25°C ~ +50°C (-13°F ~ +122°F)

Nonilluminated: -25°C ~ +70°C (-13°F ~ +158°F)

APPLICATIONS

- Medical
- Food Industry
- Lighting/Staging
- Communications
- Automation
- Transportation
- Defense
- Electronics
- Industrial
- Entertainment
- Security